

ISLAY BAR TABLE - IB36TA

ASSEMBLY INSTRUCTIONS

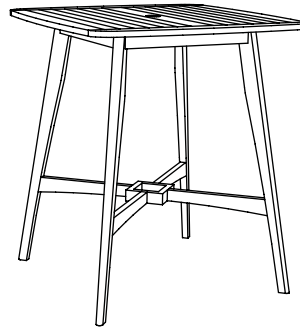

COMPONENTS

- ① Table Top
Quantity: 1

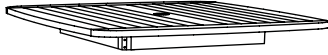

- ② Leg
Quantity: 4

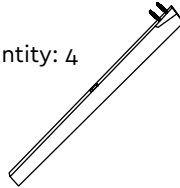

- ③ Table Top
Quantity: 1



- ④ Square
Quantity: 1

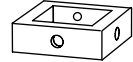

HARDWARE

- A 6 mm x 65 mm Short Machine Bolt
Quantity: 4



- B 6 mm x 100 mm Long Machine Bolt
Quantity: 4



- C Guiding Bolt
Quantity: 1



- D Barrel Nut
Quantity: 1



- E Flat Washer
Quantity: 1



- F Hexagon Nut
Quantity: 1



- G Allen Wrench
Quantity: 2



- H Hexagon Head Wrench
Quantity: 1

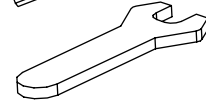

FINISHING ITEMS

Medium Grit Sandpaper

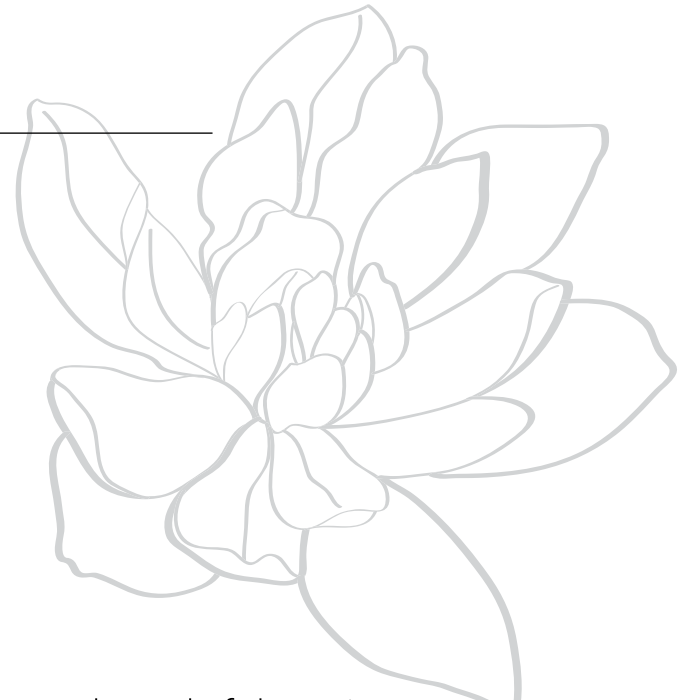

Thoughtful Design **MADE RIGHT**

INSTRUCTIONS

STEP 1

First lay table top ① on a clean & protected surface, ie. cardboard or blanket. Insert the threaded rods on one leg into holes located on one corner of table top. Repeat for ALL four legs.

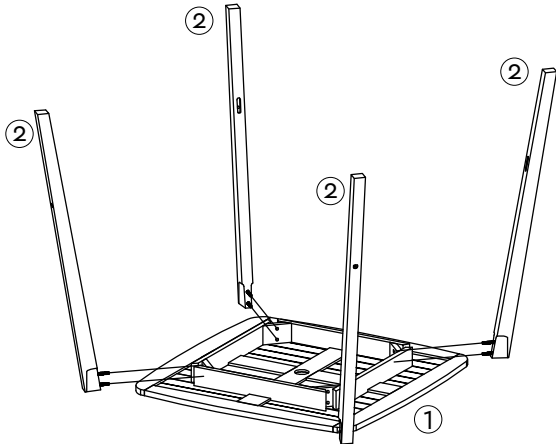

STEP 2

Secure legs to the table top using metal washer ⑤ and Hex Nut ⑥ using the Hex Head wrench provided.

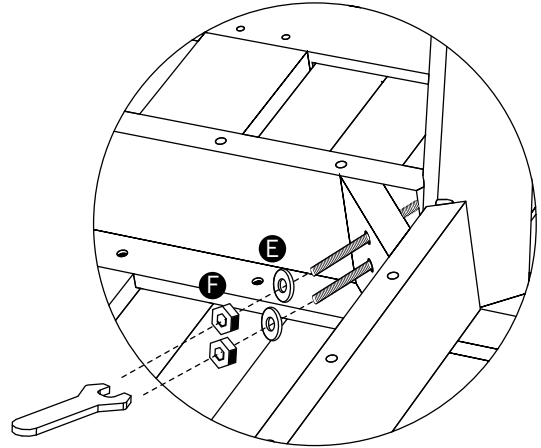

STEP 3

Insert the tenons on the leg stretchers ③ into the mortise holes of the leg. Secure by using the LONG bolt ⑧ and barrel nut ⑨ shown.

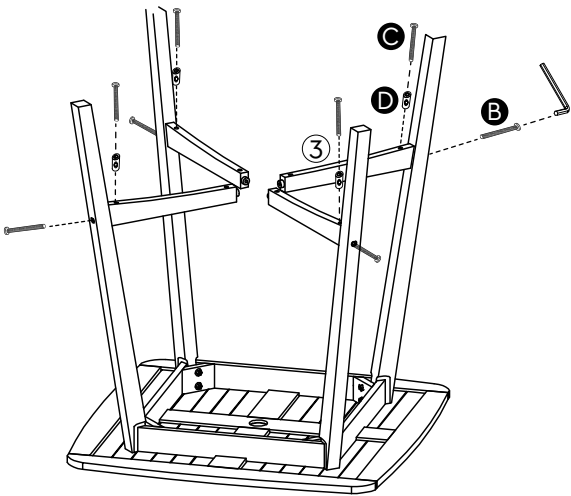

STEP 4

Insert square ④ into the assembled legs as shown. Carefully separate the four legs to allow the square to be inserted into place.

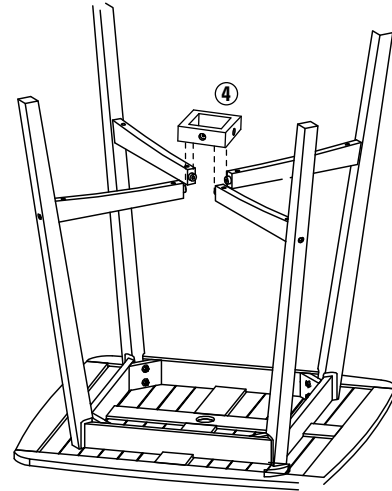

STEP 3 (detail)

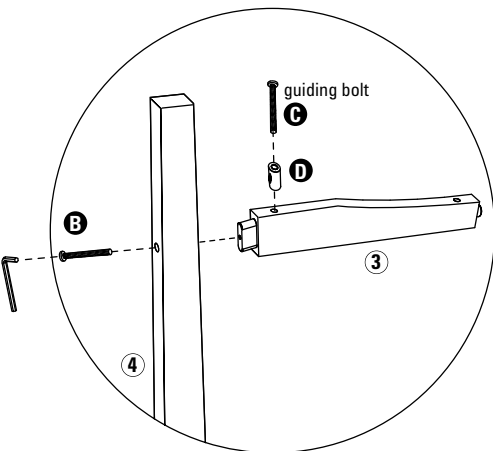

Step 4 (detail)

Using the SHORT 65 mm bolt ⑩ and barrel nut ⑪, secure square to legs.

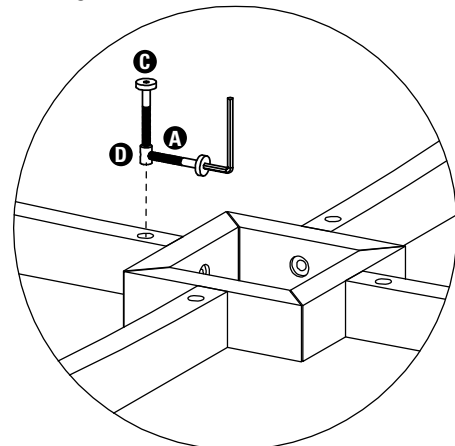

How to align barrel nuts and bolts.

Insert a guiding bolt into the end of a barrel nut. Align the barrel nut inside of the component with the bolt used to connect the components. Once the component bolt is aligned and threaded, simply pull the guiding bolt from the end of the barrel nut.

