

MERA LOVESEAT

ASSEMBLY INSTRUCTIONS

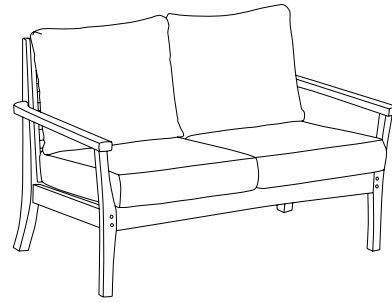

COMPONENTS

① Right Arm with Leg  
Quantity: 1

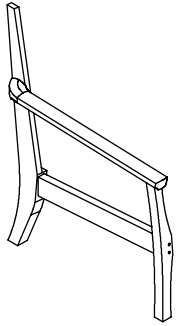

② Left Arm with Leg  
Quantity: 1

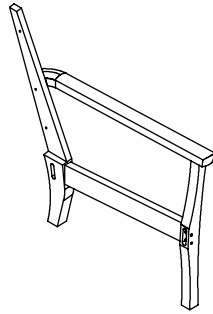

③ Backrest  
Quantity: 1

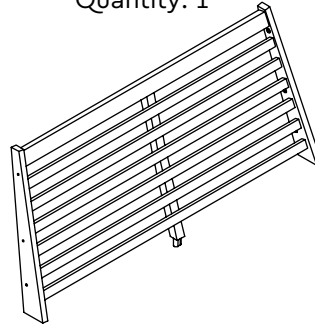

④ Seat  
Quantity: 1

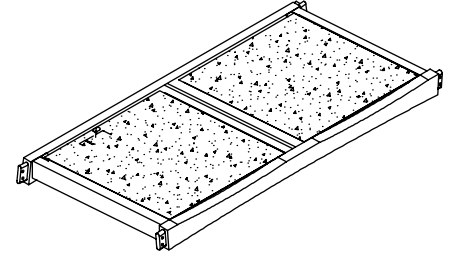

HARDWARE

A Machine Bolt  
Quantity: 6

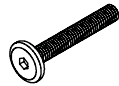

B Wooden Dowel  
Quantity: 9



C Allen Wrench  
Quantity: 1

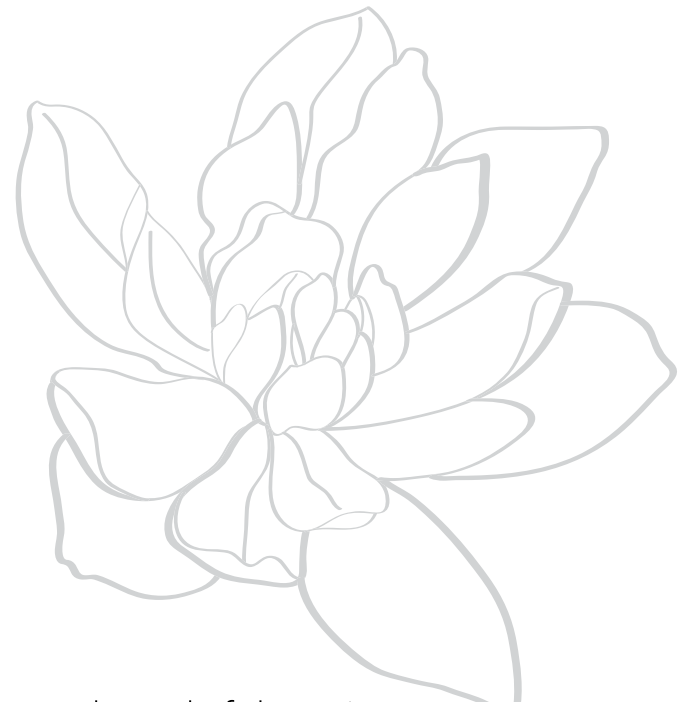
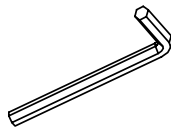

Thoughtful Design **MADE RIGHT**

# INSTRUCTIONS

## STEP 1

Insert tenons of seat assembly ④ into mortises of arm & leg frames ①②. Left and right angled tenons connect to the BACK LEGS.

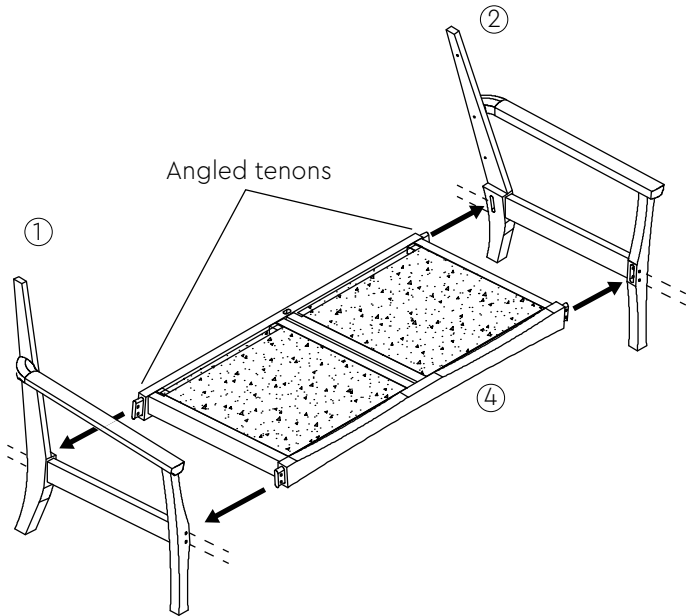

## STEP 2

Remove center dowel from back seat rail. Insert backrest ③ into assembly, aligning with the top of arm & leg frame top. Attach with 6 machine bolts and tighten firmly.

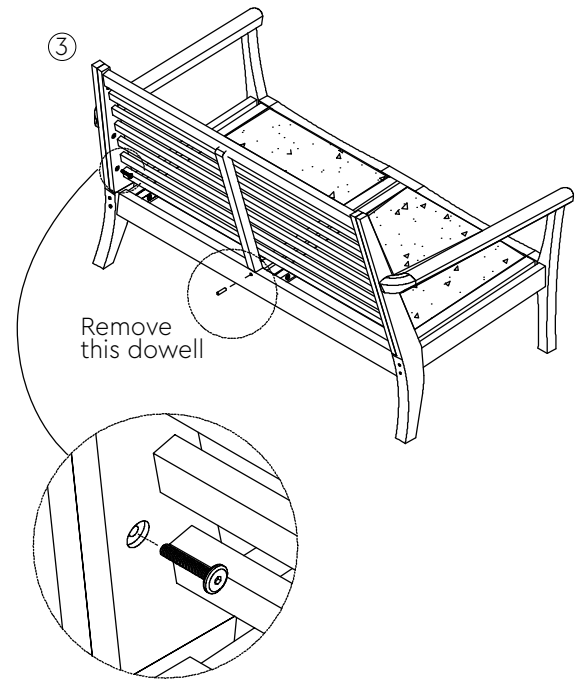

## STEP 3

Insert dowel plugs into all 4 legs and center back rail. Push in firmly until flush with surface.

